

• Assembly of Part. S0618

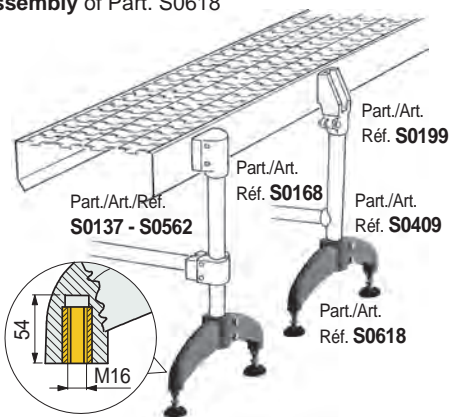

Detail of the insert for the levels.

• Sliding load

• Max applicable load

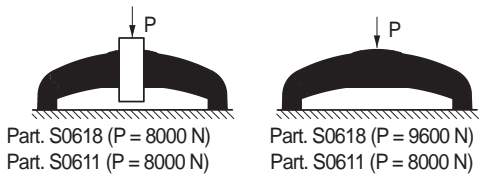

Part. S0618 (P = 8000 N)
Part. S0611 (P = 8000 N)

Part. S0618 (P = 9600 N)
Part. S0611 (P = 8000 N)

Tests performed at tightening torque:
3,6 Kgm (Part. S0618), 2,5 Kgm (Part. S0611)

• Types of levelers that can be used

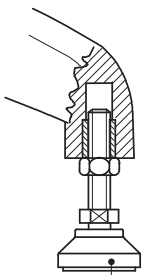

Part./Art./Réf. R0098 - R0133 - R0323

• Assembly of Part. S0611

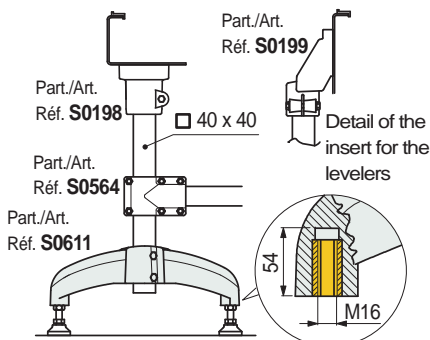

• Part. S0611 available versions

Closed version
Easy to clean

Open versionload



■ Support base (bipod)

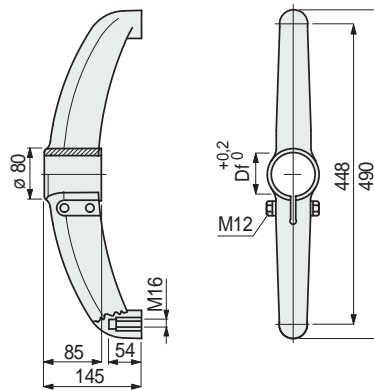

Tube dimensions
mm

Bore dia.
Df
mm

Code

Bolts in austenitic stainless steel

38,1	38,1	624282
42,4 (1"¼)	42,4	624292
48,3 (1"½)	48,3	624302
50,8	50,8	624312
60,3 (2")	60,3	624322

Bolts in zinc plated steel

38,1	38,1	638792
42,4 (1"¼)	42,4	638802
48,3 (1"½)	48,3	638812
50,8	50,8	638822
60,3 (2")	60,3	638832

- Material: support base in reinforced polyamide PA FV (black), brass threaded bushings.
- Weight: 1,05 Kg.
- Max recommended tightening torque: 3,6 Kgm.
- Packaging: 12 pieces.

■ Support base (bipod)

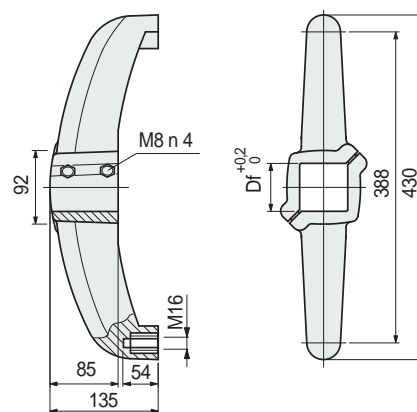

Tube dimensions
mm

Bore
Df
mm

Code

Closed version Open version

∅ 40 x 40	∅ 40	615542	616082
∅ 50 x 50	∅ 50	615552	616092
∅ 60 x 60	∅ 60	615562	616102

- Material: support base in reinforced polyamide PA FV (black), bolts in austenitic stainless steel, tightening bushes in nickel plated brass, brass threaded bushings.
- Max recommended tightening torque: 2,5 Kgm.
- Weight: 0,9 Kg.
- Packaging: 10 pieces (20 half bases).

Part. S0618



For round tubes

Part. S0611



For square tubes

● Best Seller

● Standard

● On request: minimum quantity may apply. Consult our Customer Service for availability.

Item code for order = Part. + Code